



**Suzhou Yuyue Medical Technology Co., Ltd.**

No.9 Jinfeng Road, Suzhou Science & Technology Town, 215163

Suzhou, Jiangsu, PRC

Tel: +86-512-67373001

web address: [www.yuyue.com.cn](http://www.yuyue.com.cn)



**Metrax GmbH**

Add: Rheinwaldstr. 22, 78628 Rottweil, Germany



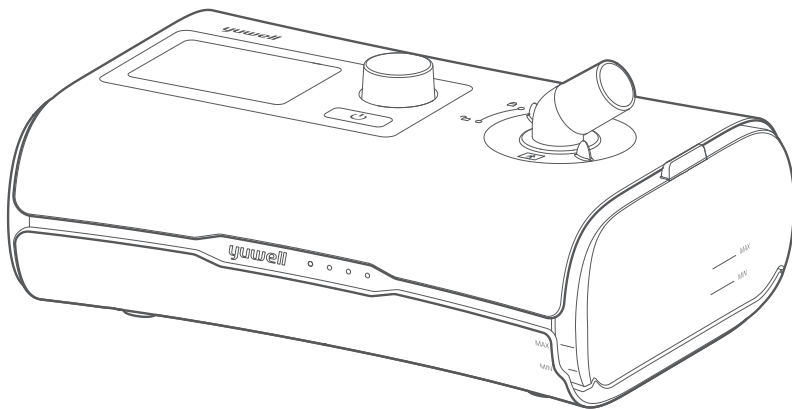

BreathCare PAP  
Positive Airway Pressure Units



## **Welcome**

The YH-350 is Yuwell's Continuous Positive Airway Pressure (CPAP) device.

The YH-550 is Yuwell's auto-adjusting pressure device.



## **Warning**

Read this entire user manual before using the device.



## **Caution**

This device is restricted to sale by or on the order of a physician.

# Content

1. Indications for use.....	01
2. Contraindications .....	01
3. Warnings .....	01
4. Precautions .....	04
5. Adverse reactions .....	04
6. Package table .....	05
7. Picture and explanation for product .....	05
8. Explanation of button .....	06
9. Installation .....	07
10. Therapy .....	09
11. Function.....	10
12. Caring for your device .....	16
13. Therapy data .....	20
14. Traveling .....	22
15. Trouble shooting .....	22
16. Specified of technology .....	24
17. Symbols.....	28
18. Limited warranty .....	30
19. Repairing .....	30
20. List of cables .....	31
21. Technical description .....	31
22. Warranty card .....	35

## 1. Indications for use

YH-350 CPAP and YH-550 self-adjusting device are indicated for the treatment of Obstructive Sleep Apnea (OSA) in patients weighing more than 66 lb (30 kg). It is intended for home and hospital/institutional use. YH-350 CPAP and YH-550 consist of main device, water tank, power adapter and cable. Mask and air tube are purchased.

## 2. Contraindications

Positive airway pressure therapy may be contraindicated in some patients with the following pre-existing conditions:

Severe bullous lung disease, pneumothorax, pathologically low blood pressure, dehydration, cerebrospinal fluid leak, recent cranial surgery, or trauma

## 3. Warnings

- Do not maintain the device while it is in use, otherwise it may lead to unacceptable risk.
- Do not modify this equipment without authorization of the manufacturer or open this device by yourself, contact your provider or Yuwell when the device need to be repaired.
- This device cannot be used for life support. It may be shut down by turning off the electricity, but no unacceptable risk will happen.
- The device can't be used in the environment where the air is mixed with flammable anesthetic gases or nitrous oxide gases. (Non-AP and Non-APG series PAP)
- The sources of oxygen must be located more than 1 m from the device to avoid the risk of fire and burns.
- Supplemental oxygen must not be used while smoking or in the presence of an open flame.
- Always make sure that the device is turned on and airflow generated before the oxygen supply is turned on. Always turn the oxygen supply off before the device is turned off, so that unused oxygen will not accumulate within the device enclosure or create a risk of fire.
- Make sure that you arrange the cables and air tube so that they will not twist around the head or neck. Otherwise it may result in strangulation.

- If you notice any unexplained change in the performance of the device, if it is making unusual sounds, if the device or the power supply are dropped or mishandled, or if the enclosure is broken, discontinue use and power off the equipment, then contact your provider or Yuwell.
- Do not place the device where it can be bumped or where someone is likely to trip over the power cord.
- Do not block the air tube and/or air inlet of the device while in operation otherwise it could cause overheating of the device.
- Keep the area around the device dry, clean and clear of anything (e.g. clothes, bedding, lint, dust or direct sunlight) that could block the air inlet, cover the power supply unit, affect patients' breathing or reduce the life of device.
- Place the device on the stable table. Placing device on the soft, out of flatness surface is forbidden.
- Keep the device far away from water.
- Make sure the power cord and plug are in good condition and the equipment is not damaged.
- Keep the power cord away from hot surfaces.
- Beware of electrocution. Do not immerse the device, power supply or power cord in water. If liquids are spilled into or onto the device. Unplug the device and let the parts dry naturally and contact your provider or Yuwell.
- Always unplug the device before cleaning and make sure that all parts are dry before plugging it back in.
- This device cannot be used for multiple patients.
- Use of this equipment adjacent to or stacked with other equipment should be avoided because it could result in improper operation. If such use is necessary, this equipment and the other equipment should be observed to verify that they are operating normally.
- Use of accessories, transducers and cables other than those specified or provided by the manufacturer of this equipment could result in increased electromagnetic emissions or decreased electromagnetic immunity of this equipment and result in improper operation.
- Portable RF communications equipment (including peripherals such as antenna cables and external antennas) should be used no closer than 30 cm (12 inches) to any part of the device, including cables specified by the manufacturer. Otherwise, degradation of the performance of this equipment

could result.

- Interconnection of this equipment to other equipment which is not the supply one is forbidden.
- Nebulisation or humidification can increase the resistance of breathing system filters and the operator must monitor the breathing system filter frequently for increased resistance and blockage to ensure the delivery of the therapeutic pressure.
- Failure to use a mask or accessory that minimizes rebreathing of carbon dioxide or permits spontaneous breathing can cause asphyxiation.
- Keep device far away from the following environments, e.g. magnetic fields, electromagnetic fields, external electrical influences, electrostatic discharge, pressure or variations in pressure, acceleration, thermal ignition sources and so on.
- Do not block the several holes in your mask, otherwise it will result in strangulation.
- Humidity performance of the device can be compromised when used outside the specified ambient temperature range or humidity range.
- The performance of the device can be compromised when exposed to environment, for example, electrocautery, electrosurgery, defibrillation, X-ray(gamma radiation), infrared radiation, conducted transient magnetic fields, magnetic resonance imaging (MRI), and radiofrequency interference.
- When the device is used near the children or disabled persons, the device must be supervised. Do not let the children or disabled persons inhale or swallow small parts. Otherwise, it may result in choking.
- Keep the area around the device dry, clean and clear of anything (eg, pets, pests or children) that could affect the device hygiene, drop the device, and so on.
- The device is intended for single patient use only. Do not let others use it.
- Covering breathing tubes with a blanket or heating them in an incubator or with an overhead heater can affect the quality of the therapy or injure the patient.
- Do not use the humidifier above an altitude of 3000 meters or outside a temperature of +5°C ~35°C . Using the humidifier outside of this temperature range or above this altitude can affect the humidifier performance.
- Prevent disconnection of the tubing or tubing system during use, especially during ambulatory use, only tubes in compliance with ISO 5367 or ISO 80601-2-74 should be used.

## 4. Precautions

- Using only Yuwell part and accessories with device. Non-Yuwell parts may reduce effectiveness of the treatment and/or damage the device.
- Use only vented masks recommended by Yuwell or by your doctor with this device. Fitting the mask without the device blowing air can result in rebreathing of exhaled air. Make sure that the mask vent holes are kept clear and unblocked to maintain the flow of the fresh air into the mask.
- If you use the humidifier, always place the device on a level surface lower than your head to prevent the mask and air tube from filling with water.
- Leave the water tank to cool for ten minutes before handling to allow the water to cool and to make sure that the water tank is not too hot to touch.
- Make sure that the water tank is empty before transporting the device.
- The proper placement and positioning of the mask on the face is critical to the consistent operation of this equipment.
- Not intended for use with patient whose upper airways have been bypassed.
- The time required for the device to warm from the minimum storage temperature between uses until the device is ready for its intended use when the ambient temperature is 20 °C is about 2 hours.
- The time required for the device to cool from the maximum storage temperature between uses until the device is ready for its intended use when the ambient temperature is 20°C is about 2 hours.
- This device is not intended for children, and patients who are physically or mentally deficient can't use the device without assistance or supervision.
- The patient is an intended operator at home.

## 5. Adverse reactions

You should report unusual chest pain, severe headache, or increased breathlessness to your prescribing physician. An acute upper respiratory tract infection may require temporary discontinuation of treatment.

The following adverse reactions may arise during the course of therapy with the device:

- drying of the nose, mouth, or throat

- nosebleed
- bloating
- ear or sinus discomfort
- eye irritation
- skin rashes

## 6. Package table

Name	Quantity	Name	Quantity
Main device	1	Mask(with mask accessories)	1
Water tank	1	Air filter	2
Air tube	1	SD card(optional)	1
Power adapter and Cable (as part of the main device)	1	User manual	1
Bag	1		

## 7. Picture and explanation for product

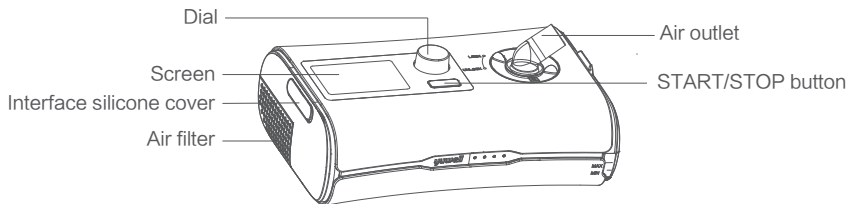

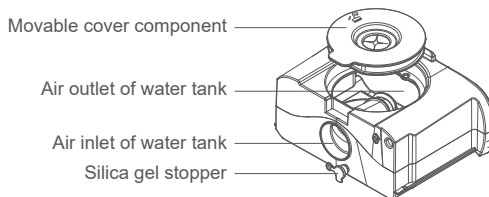
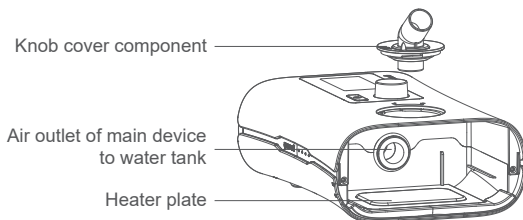
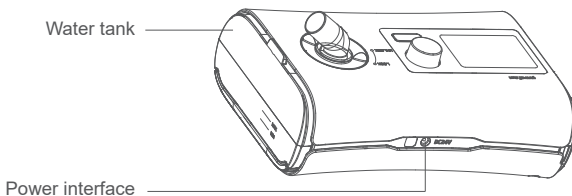

## 8. Explanation of button



**START/ STOP button:** Press to start /stop





**Dial:** Turn to navigate the menu and press to select an option. Turn to adjust the options and press to save your choice.

## 9. Installation

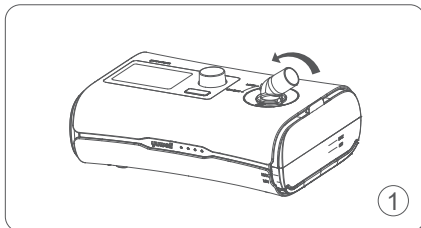
The following section will help you install your device by yourself.



1. Place the device on a stable level surface; Rotate the knob cover component from the  to .

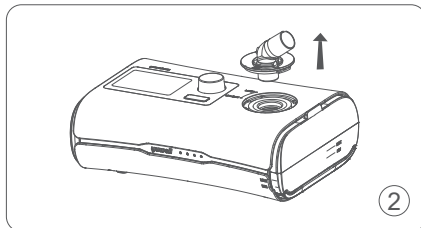

2. Pull the knob cover component out.

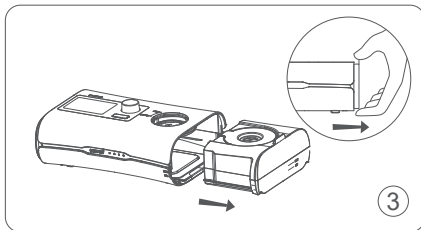

3. Press the water tank gently and pull it away from the device.

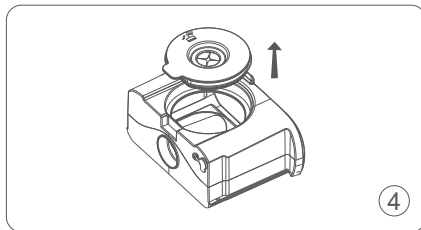

4. Open the movable cover component.

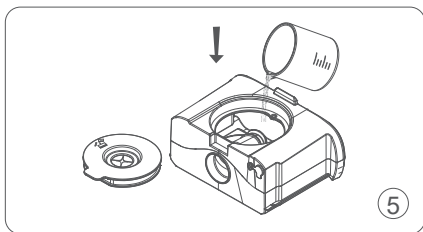

5. Fill the distilled water into the water tank, please notice that do not place the hot water into it.

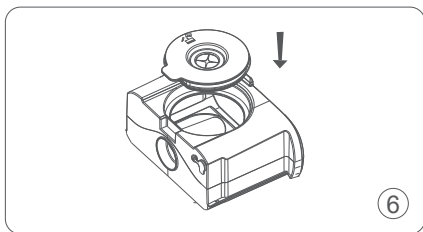

6. Close the movable cover component.

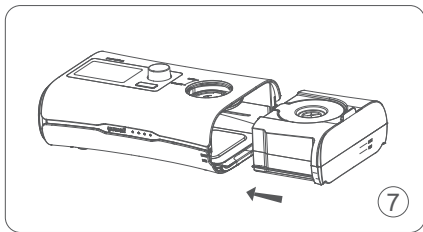

7. Insert it into the side of the device.

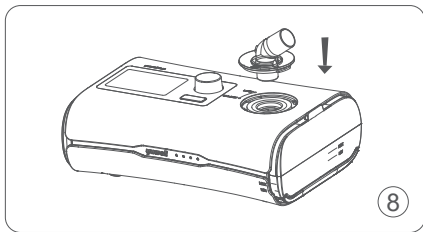

8. Close the knob cover component.

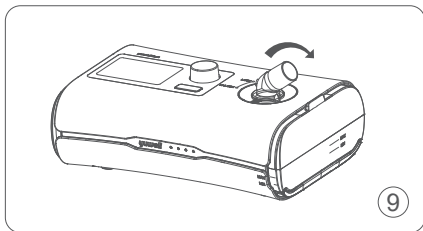

9. Rotate the knob cover component from the  to .

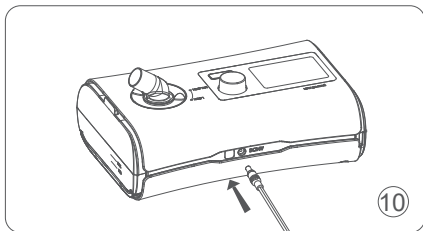

10. Plug the power connector into the rear of the device.

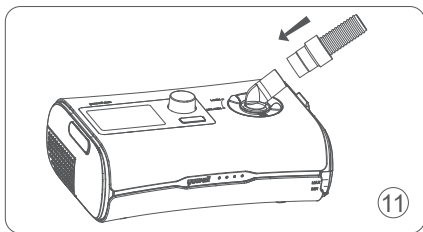

11. Connect the air tube firmly to the air outlet located on the top of the device.

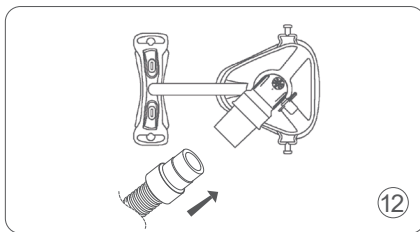

12. Connect the free end of the air tube firmly onto the mask; See the mask user guide for detailed information.

### **⚠ Caution:**

- Do not add the distilled water above the maximum water level mark, in case the water may enter the air tube and the device.
- Please change the distilled water in the water tank every day.
- Appliance coupler or mains plug is used as the isolation means from mains supply, not to position the equipment so that it is difficult to operate the disconnection device.
- When the humidity level is 6 and the therapy pressure is 20 cmH<sub>2</sub>O, 8 hours is an expected duration of operation between refills.

## **10. Therapy**

### **► 10.1 Start therapy**

- ① Power on your device;
- ② Fit your mask;
- ③ Press START/ STOP button or breathe normally if Smart Start/Stop is enabled, therapy will start.
  - During the therapy, the real-time average pressure, the set pressure, the ramp time (min), and the humidity level will all be displayed on the screen;
  - During the ramp time, the pressure increases gradually until the setting pressure has been reached;

- The screen backlight will turn off automatically after two minutes of no action. You can press any button to turn it back on.

Info	Setup
Humidity	Ramp

Picture 1-1: Home page

Pressure 6.0 cmH2O	CPAP
	7.0
	Ramp: 15
	Humidity: 6

Picture 1-2: therapy page

### **Caution**

When the level of the humidity is 1-6 and the device is delivering gas pressure, the heating plate is heating (including the situations that the screen shows “Large Leakage” and the backlight of the screen is off). When the level of the humidity is 0, the heat plate is not heating. Also if the device is not delivering gas pressure, the heat plate will not heat either.

### ► **10.2 Stop therapy**

- ① Remove your mask first;
- ② Press the Start / STOP button or if Smart Start/Stop is enabled, therapy will stop automatically after about one minute;
- ③ To power off your device, please separate your plug from the electricity.

## 11. Function

### ► **11.1 Function that patient can safely use**

#### ① Information

You can read summary of sleep report on information page. Following parameters will be displayed

- AHI: Indicates the number of apneas and hypopneas per hour.
- Used Time (h): The time duration of the last therapy (h).
- Treatment Time (h): The time of the patient wore the mask (h).

- Average Pressure: The average pressure of the last therapy (cmH<sub>2</sub>O / hPa).
- Average Leak volume: Average air leak volume per minute of the last therapy (L/min).
- Total Time (h): Total time of therapy (h).
- Uploaded/Total: Number of uploaded treatment data / the total amount of treatment data.
- WIFI Signal: The WIFI signal has five states: Strong, Medium, Weak, No WIFI, No Server, OFF.
- P90: The pressure for the 90 percent of the last therapy (cmH<sub>2</sub>O / hPa).
- Version: The version of software used for the device.
- SN: The serial number of the device.

AHI	0.0
Used Time(h)	0.4
Treatment Time(h)	0.4
Average Pressure	20.0

Picture2-1:Info

Average Leak Volume	0.0
Total Time(h)	0.5
Uploaded/Total	0/1
WIFI Signal	OFF

Picture 2-2:Info

P90	20.0
Version	S1.0.01.35E1CW0
SN	YH350A*214650002
Back<<	

Picture 2-3: Info

## ② Ramp

Ramp time is designed to make you more comfortable at the beginning of the therapy; you can adjust the ramp time from 0 to 45 minutes with an increment of 5 minutes.

To adjust the Ramp:

- Highlight the "Ramp" and press dial to see your current setting;
- Press dial and rotate it to adjust your setting;
- Press dial to save your change.

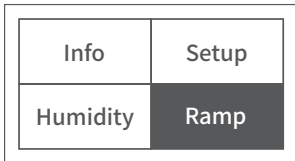

Picture 3-1: Home

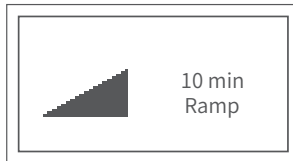

Picture 3-2: Ramp

### ③ Humidity

Humidifier is designed to moisten the air and is designed to make therapy more comfortable. If you are getting a dry nose or mouth, turn up the humidity. If you are getting any moisture in your mask, turn down the humidity. You can set Humidity level between 0 to 6, where 0 means this function is disabled, 1 is the lowest humidity setting and 6 is the highest humidity setting.

The temperature of each level on the heater plate is as following (accuracy is  $\pm 4^{\circ}\text{C}$ )

0:OFF    1:33°C    2:35°C    3:40°C    4:45°C    5:50°C    6:55°C

This temperature has been tested with empty water tank, with 10 minutes preheating time.

To adjust the humidity level:

- Highlight the "Humidity", press dial to enter the humidity page;
- Rotate it to choose humidity level, then press dial again to save your change and back to home page;
- You can change humidity level at any time during therapy.

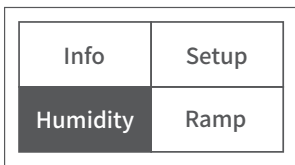

Picture4-1: Home



Picture4-2: Humidity

### ④ Setup

- Sound Reminder: When this function is enabled, the device will give a sound reminder when an abnormal air leakage occurs.
- Smart Start/Stop: When this function is enabled, therapy starts automatically when you breathe into your mask. After you remove your mask, it will stop automatically in one minute.
- FPS Level: When this function is enabled, you may feel easier to breathe out; It helps you get used to the therapy. It has 4 levels of FPS, 0 means this function is disabled, 1 is the lowest level of FPS, and 3 is the highest level of FPS. The higher FPS level means more comfortable expiration you will get.

- Upload data: When Upload Data is turned on, the device will enable the data upload function.
- Bluetooth: After Bluetooth is turned on, the Bluetooth function is enabled.
- Date: Adjust the date (year, month, day) displayed on the device.
- Time: Adjust the time (hour, minute) displayed on the device.
- Language: You can choose English or Chinese.
- Filter Cotton Reminder: When this function is enabled, this can remind you to check and change the filter.
- Reset: When this function is enabled, parameters of the device will be reset to the factory defaults.

Info	Setup
Humidity	Ramp

Picture 5-1: Home

Sound Reminder	OFF
Smart Start/Stop	OFF
FPS Level	0
Upload data	OFF

Picture 5-2: Setup

Bluetooth	ON
Date	2022-01...
Time	15:02
Language	EN

Picture5-3: Setup

Language	EN
Filter Cotton Reminder	OFF
Reset	>>
Back<<	

Picture 5-4: Setup

## ► 11.2 Function that patient must use under the direction of doctor (Clinical menu)

The patient should use the device by the direction of physician.

### ① Set Mode (CPAP or APAP)

- At the home page, press and hold START/ STOP button and dial at the same time for three seconds,

the clinical menu will be shown on screen.

- Rotate the dial, highlight the "Mode", and then select CPAP or APAP.
- After mode setting, press dial to save your change.
- Highlight the "Back", press dial to back to home page.

### ② Set Pressure

- At clinical page, choose "CPAP" mode, Highlight "Initial Pressure" or "Therapy Pressure", press and rotate dial to set suitable value.
- You can rotate the dial to the right or to the left to rise or decrease therapy pressure (each step is 0.5 cmH<sub>2</sub>O / hPa).
- After setting therapy pressure, press dial to save your change.
- Highlight the "Back", press dial to back to home page.
- You can set "Max Pressure", "Min Pressure", "Initial Pressure" and "Therapy Pressure" of APAP mode according to above method.



### Notice

When you try to make the Max pressure lower than Min pressure, Initial pressure or Therapy pressure, these pressures will be equal to the Max pressure.

### ③ Set Pressure Unit

- At clinical page, highlight " Pressure Unit".
- Rotate the dial to the right or left, set your pressure unit (cmH<sub>2</sub>O or hPa).
- After setting pressure unit, highlight the "Back", press dial to back to home page.

### ④ Set FPS Level

- At clinical page, Highlight "FPS Level".
- Rotate the dial to the right or left, set your level of FPS (0-3 level).
- After setting level of FPS, highlight the "Back", press dial to back to home page.

### ⑤ Set Ramp

- At clinical page, Highlight "Ramp".
- Rotate the dial to the right or left, set your ramp time (0-45 minutes, step value is 5 minutes).
- After setting Ramp, highlight the "Back", press dial to back to home page.

### ⑥ Set Humidity Level

- At clinical page, Highlight "Humidity".
- Rotate the dial to the right or left, set your humidity level (0-6 level, step value is 1 level).
- After setting humidity level, highlight the "Back", press dial to back to home page.

### ⑦ Erase Data

- At clinical page, Highlight "Erase Data" .
- Press the dial to the page where you can choose Yes or No.
- If you choose Yes, your therapy data will all be erased.



### Caution:

During your therapy, you can go to clinical menu by pressing and holding START/ STOP button and dial at the same time for three seconds. Section 11.2 clinical menu tells the method to change all the parameters.

Mode	CPAP
Inital Pressure	4.0
Therapy Pressure	20.0
Pressure Unit	cmH2O

Picture 6: Clinical menu

## 12. Caring for your device

It is important that you regularly clean your device to make sure you receive optimal therapy. The following sections will help you with disassembling, cleaning, checking, reassembling your device.

### ► 12.1 Disassembling

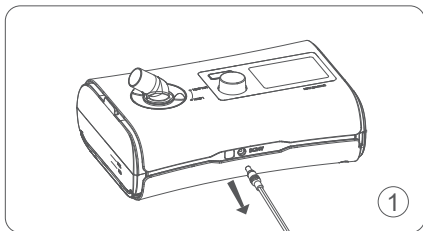

1. Pull the power connector out of device.

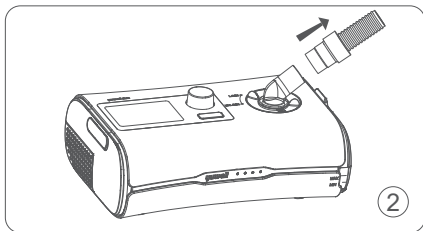

2. Hold the cuff of the air tubing and gently pull it away from device

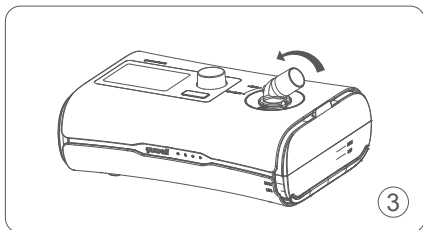

3. Rotate the knob cover component from the  to .

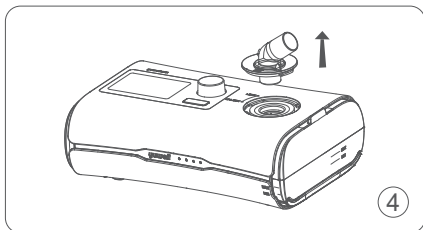

4. Pull the knob cover component out.

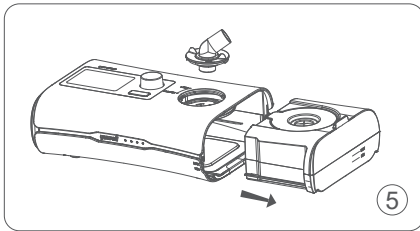

5. Press the water tank gently and pull it away from the device.

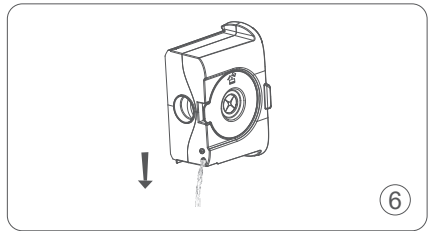

6. Open the silica gel stopper and discard the remaining water.

**⚠ Notice: Close the silica gel stopper after the water has been poured out.**

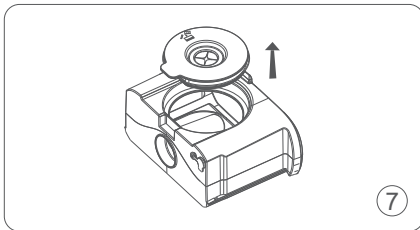

7. Open the movable cover component.

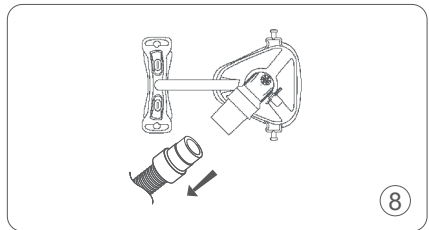

8. Hold both the cuff of the air tubing and the swivel of the mask, then gently pull apart.

**⚠ Notice: Don't pull the threaded portion of the air tubing.**

## ► 12.2 Cleaning

### **⚠ WARNINGS!**

- Regular cleaning of the device and its accessories is very important for the prevention of respiratory infections.
- To avoid electric shock, always unplug the device before cleaning.

- Use mild soap that is nontoxic to humans.
- Before cleaning, check whether the device has been disconnected from the power supply, whether the power cord has been unplugged, and whether the water tank of the device has cooled down. Make sure the plate has cooled down to room temperature, so you do not get burned.
- Do not open or modify the device. There are no user serviceable parts inside. Repairs and servicing should only be performed by an authorized service agent.

### **CAUTIONS!**

- Overheating of the materials could lead to early fatigue of these materials.
- Do not clean the device with bleach, chlorine, ozone, UV light, aromatic solution, moisturizing factor, antibacterial soaps, sesame oil, or any other methods outside of this manual.
- Do not immerse the device in any fluids.

## **12.2.1 Cleaning the Water Tank**

You can clean the water tank with a soft cloth which does not scratch the water tank (dip the soft cloth in liquid soap if necessary), rinse it thoroughly, and then wipe it dry with a soft cloth.

### **WARNINGS!**

- Emptying and cleaning the water tank daily will help prevent mold and bacteria growth.
- Allow the water in the chamber to cool down to room temperature before removing it from the device.

### **CAUTIONS!**

- Clean the water tank only after the water in it cools. Make sure that no water enters the device.
- After cleaning, rinse the water tank thoroughly in clean water to make sure that no soap residue is left; then wipe it dry with a lint-free cloth, so as to prevent calcareous accumulations.
- Inspect the water tank for any leak or damage. Replace the water tank if any damage is present.
- It is recommended to do daily cleaning of the water chamber.

## **12.2.2 Cleaning the Enclosure**

Wipe the surface of the device with a soft, slightly damp cloth.

## ⚠ CAUTIONS!

- The device can only be used after the enclosure is dry, so that no moisture enters the device.
- It is recommended to clean the enclosure once a week.

### ► 12.3 Checking

You should check power adapter and cable, water tank, air tube and air filter regularly in case of any damage.

a. Check the power adapter and cable

- Wipe the power adapter and cable with the dry compress if it is dirty.
- Replace the power adapter and cable if it is broken.

b. Check the water tank

- Replace the water tank if it is broken or cracked.
- Replace the water tank if the seal is torn or cracked.

c. Check the air tube

- Replace the air tube if there are any holes, tears or cracks.

d. Check the air filter

- Please check the air filter every week and replace the air filter at least every four weeks.
- If you find some particle blocked in the air filter, replace it more often.

To replace the air filter

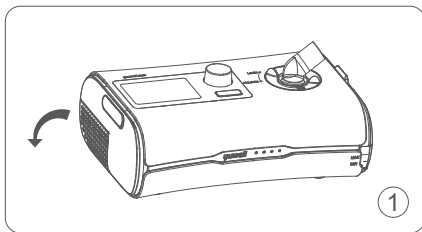

1. Open the air filter cover;

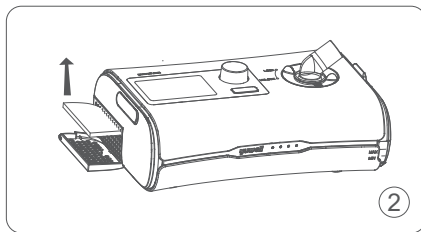

2. Remove the dirty air filter;

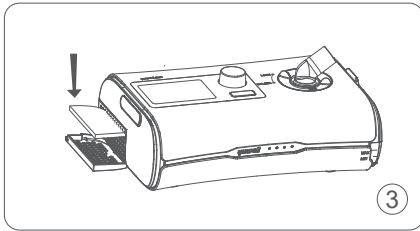

3. Place a new air filter onto the air filter cover.

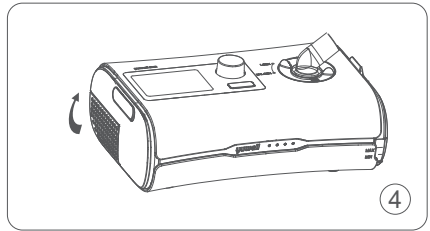

4. Close the air filter cover.

### **Caution**

Make sure the air filter is fitted at all times to prevent water and dust from entering the device.

## ► 12.4 Reassembling

After finishing all the cleaning steps, reassemble all these parts together. When the water tank and air tube are dry, you can reassemble the parts.

- Open the movable cover component and fill the distilled water into the water tank.
- Close the movable cover component, and insert it into the side of the device.
- Close the knob cover component and rotate it from to.
- Connect the air tube firmly to the air outlet located on the top of the device.
- Connect the free end of the air tube firmly onto the assembled mask.

## 13. Therapy data

Your therapy data is recorded in the device. The therapy data can be transferred to your care provider via either SD card or wireless network, so they can view and make changes to your therapy if required.

### ► 13.1 Transfer data via SD card

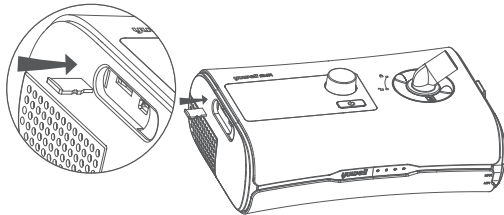

1. Open the silica gel stopper at the left side of the device;
2. After switching the device to the home page, insert the SD card into the SD card connector;
3. Remove the SD card from the device after it wrote successfully.

**⚠ Caution:**

Don't use the interface of the mini USB, since it is reserved for the manufacturer.

**▶ 13.2 Transfer data via the wireless**

If the Upload Data is turned on and the wireless network connection is secured, the device will automatically upload the therapy data after each treatment.

There are an indication on the new page to show the status of data upload:

- Uploading: The therapy data is being sent
- Succeed: The therapy data has been sent successfully
- Fail: Failed to send the therapy data
- Fail 01: Error data
- Fail 02: Time out
- Fail 03: Server connection failed
- Fail 04: WIFI abnormal

**⚠ Notice:**

- In order to upload data successfully, please ensure that Upload Data is turned on and the wireless network connection is secured;
- If the therapy data upload failed, the device will manage to upload the therapy data again after the

data upload is turned on and the wireless connection is secured;

- You can check the progress of uploaded data in the Information page;

For the wireless connection, please read the wireless connection operation guide in detail or consult your provider or Yuwell.

## 14. Traveling

You can take your device with you wherever you go. Just keep the following in mind.

- Use the travel bag provided to prevent damage to the device.
- Empty the water tank.
- Make sure you have the appropriate power cord for the region you are traveling to. For information on purchasing, contact your provider or Yuwell.

## 15. Trouble shooting

When your device has trouble, look for the following table to find solution. Contact your physician, your provider or Yuwell if you cannot solve your problem. Do not try to open the device.

### ► 15.1 General troubleshooting

Trouble	Cause	Solution
Air is leaking from around my mask.	Mask may be fitted incorrectly; The size of the mask is not suitable.	Ensure your mask is fitted correctly. See your mask user guide to check your mask fit and seal; Please refer to the nose measurement card to choose the appropriate mask size.

I am getting a dry or blocked nose.	Humidity level may set too low; For the blocked nose: History of nasal disease; The pressure parameter may be set improperly.	Adjust the humidity level; Use after treatment by a doctor; Adjust the pressure parameter.
I am getting droplets of water on my nose, in the mask and air tube.	Humidity level may be set too high; Condensation forms in the piping mask due to cold weather.	Adjust the humidity level; Buy heated tube to solve condensation.
My mouth is very dry and uncomfortable.	Air may be escape from your mouth; The humidity level is not on or may be set too low.	You may need a chin strap to keep your mouth closed or a full face mask; Increase the humidity level.
Air pressure in my mask seems too high (it feels like I am getting too much air).	Ramp may be turned off; The pressure parameter may be set too high.	Enable your ramp option; Decrease the pressure.
Air pressure in my mask seems too low (it feels like I am not getting enough air).	Ramp may be in progress; The pressure parameter may be set too low.	Start your therapy after the setting pressure reached or turn ramp time off; Increase the pressure.
My screen is black.	After therapy start, the screen backlight went off; In other case, the power do not connect firmly.	Press dial to turn on the screen light; Check the connection of power, ensure it connect with device firmly.

My water tank is leaking.	Water tank assemble incorrectly or it is broken.	Check the water assemble correctly; Contact your provider or Yuwell if your water tank is broken.
---------------------------	--	--

## ► 15.2 Other trouble

Message in LCD	Meaning of error	Solution
ERROR 1	There is a mistake of pressure sensor	Please contact your provider or Yuwell
ERROR 2	There is a mistake of flow sensor	Please repower your device or contact your provider or Yuwell
ERROR 3	There is a mistake of temperature sensor	Please contact your provider or Yuwell
ERROR4	The protection circuit fail	Please contact your provider or Yuwell
ERROR 5	There is a parameter exceed in parameter range	Please repower the device or contact your provider or Yuwell
ERROR 6	The pressure is exceed in pressure range	Replace the filter with a new one or repower the device or contact your provider or Yuwell
ERROR 7	It is failed to supply power to the humidifier	Please contact your provider or Yuwell
ERROR 8	There is a mistake of blower	Please contact your provider or Yuwell
ERROR 9	There is a mistake of RTC (loss power)	Please adjust the time of the device or contact your provider or Yuwell

## 16. Specified of technology

Items	Specifies	
Power	Powered by adapter Input :100-240VAC, 50-60Hz,2A max Output:24V DC,2.5A	
Environment conditions	Temperature	Operate:+5°C ~35°C (+41 °F ~95 °F) ,Non-condensing Transport and storage:-20°C ~70°C (-4 °F ~158 °F) ,Non-condensing
	Humidity	Operate: relative humidity 15%-90%, Non-condensing Transport and storage: relative humidity 15%-90%, Non-condensing
	Atmospheric pressure range	700 hPa ~ 1060 hPa
	Altitude	≤ 3000 m
Protection class	Type of Protection Against Electric Shock: Class II Degree of Protection Against Ingress of Water: IP 21 (the device); IP22 (the Power adapter) Degree of Protection Against Electric Shock: Type BF Applied Part	
Mode of operation	Continuous operation	
Maximum single fault steady pressure	Device will shut down in the presence of a single fault if the steady state pressure exceeds: 40 cmH <sub>2</sub> O	
Sound	Sound pressure level	Sound pressure level measured according to ISO 80601-2-70:2015 (CPAP mode): 28±2 dB(A)
	Sound power level	Sound power level measured according to ISO 80601-2-70:2015 (CPAP mode): 36±2 dB(A)

Physical properties	Dimensions (length*width*height)	272.5 mm * 181 mm * 93 mm or 10.73" * 7.13" * 3.7"
	Weight	About 1419 g
	Air tube	Plastic hose, about 1.8m
	Maximum volume of water tank	260±10 mL
	Air outlet	22 mm (complies with ISO 5356-1:2015)
Temperature	Maximum temperature of heater plate	55°C ±4°C ( 131°F ±14.4°F )
	Cut-out	110°C (if it is damaged, return to manufacturer)
	Maximum gas temperature	43°C
Air filter	Material: Polyester non-woven fiber Average arrestance: ≥ 85% for~2.5 micron dust	
Therapy pressure	4~20 hPa (adjustable, step is 0.5 hPa) or 4~20 cmH <sub>2</sub> O	
Initial pressure	4~20 hPa (adjustable, step is 0.5 hPa) or 4~20 cmH <sub>2</sub> O	
Maximum pressure	4~20 hPa (adjustable, step is 0.5 hPa) or 4~20 cmH <sub>2</sub> O	
Minimum pressure	4~20 hPa ( ≤ maximum pressure, adjustable, step is 0.5 hPa) or 4~20 cmH <sub>2</sub> O	
Ramp	0~45 minutes (adjustable, step is 5 minutes)	

Pneumatic flow path :

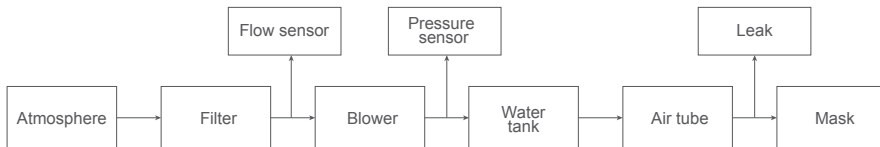

Gas leakage

2 L/min at the maximum rated pressure

Maximum flowrate

The performance of the device at set pressure according to ISO 80601-2-70:2015 is shown below:

Test pressures(hPa)	4	8	12	16	20
Average flow at the PATIENT- CONNECTION PORT (L/min)	≥ 100	≥ 100	≥ 100	≥ 100	≥ 100

















Humidifier performance

Humidification system output:  $\geq 12\text{mg/L}$  (BTPS)  
 (The humidifier belongs to Category 2 according to the standard ISO 80601-2-74:2017)  
 Relative humidity:  $\geq 50\%$

Pressure accuracy	Maximum static pressure variation according to ISO 80601-2- 70:2015 ± [2% of the full scale +4% of the set value]			
	Maximum dynamic pressure variation according to ISO 80601-2-70:2015			
	Pressure(cmH <sub>2</sub> O)	10 bpm	15 bpm	20 bpm
	4	± [2% of the full scale +4% of the set value]		
	8	± [2% of the full scale +4% of the set value]		
	12	± [2% of the full scale +4% of the set value]		
	16	± [2% of the full scale +4% of the set value]		
20	± [2% of the full scale +4% of the set value]			
Maximum limited pressure	The maximum limited pressure 20 cmH <sub>2</sub> O in normal condition 40 cmH <sub>2</sub> O under single fault Condition			
The Uncertainty of measurement:	For measures of pressure: ± 0.2 hPa For measures of flow: ± 2 L/min or ± 3% (whichever is greater)			
Expected service life	Device (excluding accessories)	5 years		
	Water tank	90 days		
	Air tube and mask	Refer to user manual of the air tube or the mask		

## 17. Symbols

### ► 17.1 The following symbols may appear on the product or packaging:

Symbol	Meaning	Symbol	Meaning
	Follow instructions for use		Start therapy / stand-by
	General warning sign		Temperature limitation for storage and transport
	Manufacturer		Type BF applied part
	Medical device		Model number
	Serial number	___ MAX	Maximum water level
	Humidity limitation		Atmospheric pressure limitation
<b>Rx Only</b>	Prescription only	___ MIN	Minimum water level
	Warning: hot surface		Class II equipment
	General warning sign		
	Country of manufacture (China) Date of manufacture is on the right side of the symbol or below it.		
	Symbol for the marking of electrical and electronics devices according to Directive 2012/19/EU		
<b>IP21</b>	Protected against access to hazardous parts with a finger and solid foreign objects of 12.5 mm in diameter and greater, protected against vertically falling water drops.		
<b>IP22</b>	Protected against access to hazardous parts with a finger and solid foreign objects of 12.5 mm in diameter and greater, protected against vertically falling water drops when enclosure tilted up to 15 degrees.		

## ► 17.2 Disposal statement:

### Warning:

Please contact local authorities, your provider or Yuwell to determine the proper method of disposal of this device.

## 18. Limited warranty

YUWELL warrants that your device shall be free from defects in material and workmanship from date of purchase for the period specified below:

Product	Warranty period
Water tank	90 days
Power adapter	1 year
Device	2 years

The quality warranty is only available to the initial customer. It is not transferable. Warranty is void on product sold, or resold, outside the original purchase, repaired by the company without accredited, and pollution caused by smoking.

Your provider or Yuwell has the interpretation about the device's warranty.

## 19. Repairing

- If your device is in trouble, please contact your provider or Yuwell. This device only can be repaired by the provider who has been authorized.
- The user should follow the instruction of cleaning and safety to guarantee that the device can be used for a long time.
- If you have troubles in setting up, using or maintaining the equipment or meet some unexpected operation or events, please contact your provider or Yuwell as well. If you want to know more information about your device, you can visit the website of YUWELL: [www.yuyue.com.cn](http://www.yuyue.com.cn)

## 20. List of cables

Name	Lengths(m)
Cable(AC)	1.5
Cable(DC)	1.2

## 21. Technical description

The device is intended both for home healthcare environment and professional healthcare facility environment.

### ► 21.1 Compliance information for Emission test

Emissions Test	Compliance
RF emissions CISPR 11	Group 1
RF emissions CISPR 11	Class B
Harmonic emissions IEC 61000-3-2	Class A
Voltage fluctuations / flicker emissions IEC 61000-3-3	Complies

### ► 21.2 Compliance information for Immunity test

Immunity Test	Compliance Level
Electrostatic discharge (ESD) IEC 61000-4-2	$\pm 8$ kV contact, $\pm 15$ kV air
Electrical fast transient / burst IEC 61000-4-4	$\pm 2$ kV for power supply lines
Surge IEC 61000-4-5	$\pm 1$ kV line(s) to line(s)

Voltage dips, short interruptions and voltage variations on power supply input lines IEC 61000-4-11	0% $U_T$ ; 0.5 cycle At 0°, 45°, 90°, 135°, 180°, 225°, 270° and 315° 0% $U_T$ ; 1 cycle 70% $U_T$ ; 25 / 30 cycle At 0° 0% $U_T$ ; 250 / 300 cycle
Power frequency (50Hz) magnetic field IEC 61000-4-8	30 A/m
Radiated RF EM fields	10V/m 80 MHz-2,7 GHz 80 % AM at 1 kHz
Conducted disturbances induced by RF fields	3V 0, 15 MHz-80 MHz 6V in ISM and amateur radio bands between 0, 15 MHz and 80 MHz 80% AM at 1 kHz
NOTE $U_T$ is the a.c mains voltage prior to application of the test level.	

Test specifications for enclosure port immunity to RF wireless communications equipment.

Test frequency (MHz)	Band <sup>a)</sup> (MHz)	Service <sup>a)</sup>	Modulation <sup>b)</sup>	Maximum power (W)	Distance (m)	IMMUNITY TEST LEVEL (V/m)
385	380-390	TETRA 400	Pulse modulation <sup>b)</sup> 18Hz	1,8	0,3	27

450	430-470	GMRS 460 FRS 460	FM <sup>a)</sup> ±5kHz deviation 1 kHz sine	2	0,3	28
710	704-787	LTE Band 13,17	Pulse modulation <sup>b)</sup> 217Hz	0,2	0,3	9
745						
780						
810	800-960	GSM 800/900,TETRA 800, iDEN 820, CDMA 850, LTE Band 5	Pulse modulation <sup>b)</sup> 18Hz	2	0,3	28
870						
930						
1 720	1 700-1 990	GSM 1800; CDMA 1900; GSM 1900; DECT; LTE Band 1,3,4,25;UMTS	Pulse modulation <sup>b)</sup> 217Hz	2	0,3	28
1 845						
1 970						
2 450	2 400-2 570	Bluetooth, WLAN, 802.11 b/g/n, RFID 2450, LTE Band 7	Pulse modulation <sup>b)</sup> 217Hz	2	0,3	28
5 240	5 100-5 800	WLAN 802.11 a/n	Pulse modulation <sup>b)</sup> 217Hz	0,2	0,3	9
5 500						
5 785						

#### NOTE

If it's necessary to achieve the IMMUNITY TEST LEVEL, the distance between the transmitting antenna and the ME EQUIPMENT or ME SYSTEM may be reduced to 1 m. The 1 m test distance is permitted by IEC 61000-4-3.

- a) For some services, only the uplink frequencies are included.  
b) The carrier shall be modulated using a 50 % duty cycle square wave signal.  
c) As an alternative to FM modulation, 50 % pulse modulation at 18 Hz may be used because while it does not represent actual modulation, it would be worst case.

### ► 21.3 Precautions According to IEC 60601

According to IEC 60601-1-2:2014, the device complies with all applicable electromagnetic compatibility requirements (EMC) .It may have harmful interference with other devices if you do not follow the instructions. However, there is not certain it has not interference with other devices if you follow the instructions. If it does have interference with other device, you can amend interference by the following methods.

- Enlarge the distance between this device and other device.
- Connect the two devices with different power socket.
- Ask Yuwell engineer for help.

Essential performance and basic safety testing should be done every two years. If your device needs to be done, please contact your provider or Yuwell. This device only can be tested by the provider who has been authorized.

## 22. Warranty card

**yuwell**

### BreathCare PAP Warranty Card

Feedback Couplet

Contact _____	Department _____	User _____
Add. _____		
Diagnose _____	Tel. _____	

Model _____	SN _____
Invoice number _____	Purchasing date _____
Dealer _____	

This limited warranty does not cover:

- Any damage caused as a result of improper use, abuse, modification or alteration of the product.
- Repairs carried out by any service organizations that have not been expressly authorized by Yuwell to perform such repairs.
- Any damage caused as accident, act of god or human factor.
- Product which is not involved in quality warranty sheet.

User sign \_\_\_\_\_

Date \_\_\_\_\_



## BreathCare PAP Warranty Card

Customer Couplet

Contact _____	Department _____	User _____
Add. _____		
Diagnose _____	Tel. _____	

Model _____	SN _____
Invoice number _____	Purchasing date _____
Dealer _____	

This limited warranty does not cover:

- Any damage caused as a result of improper use, abuse, modification or alteration of the product.
- Repairs carried out by any service organizations that have not been expressly authorized by Yuwell to perform such repairs.
- Any damage caused as accident, act of god or human factor.
- Product which is not involved in quality warranty sheet.

User sign \_\_\_\_\_

Date \_\_\_\_\_